

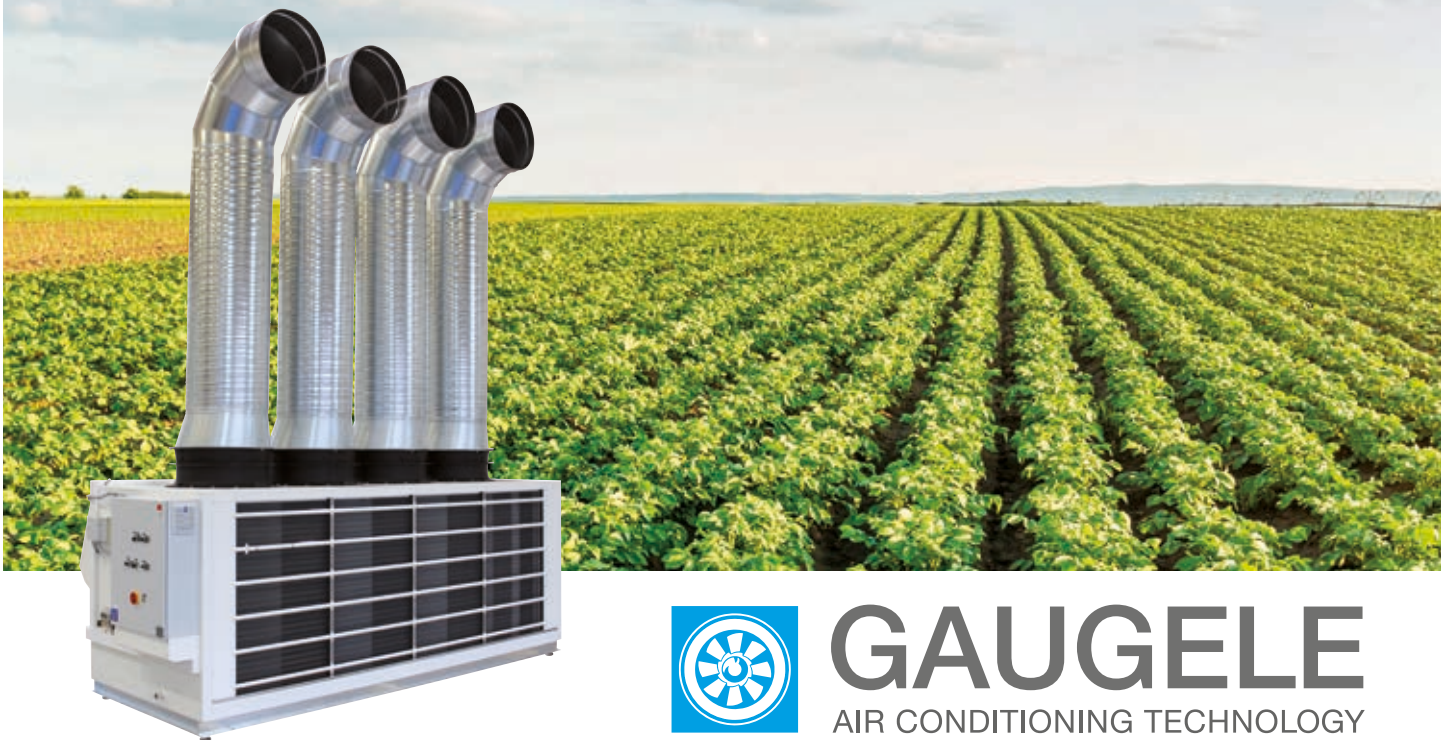

# Your Specialist for Economical and Smart Complete Storage Solutions

[www.gaugele.com](http://www.gaugele.com)



**GAUGELE**  
AIR CONDITIONING TECHNOLOGY





— At Gaugele, ensuring the optimal storage climate for your products is paramount. We are eager to assist you in selecting the storage concept which best suits your needs. In this process, we consider your preferences and the local conditions, working alongside you to devise the ideal solution.”

---

**HERMANN GAUGELE**  
Company Owner

Welcome

---

**YESTERDAY AND TODAY**

When Hermann Gaugele began developing fans for hay drying back in 1950, he had little inkling that his company would one day stand among the market leaders in agricultural storage and climate technology.



# Successful Product Developments since 1950

At Gaugele, innovation is tradition: for over 70 years, this family business has combined pioneering spirit, sophisticated technology, and expert engineering know-how. Thus, we always have new ideas at hand to make your warehouses even better.

**Specifically, 'better' means:  
more reliable, more efficient, and more cost-effective.**

We provide meticulously crafted concepts for every type of warehouse. Custom-engineered ventilation, cooling and control systems, along with tailored sorting and conveying technologies, cater to all storage configurations from crates (loose bulk products) to box storage. Be it a turnkey new building, a renovation, or modernisation of your storage, we have got you covered.

Besides, we place a high emphasis on quality management according to EU guidelines. Our agricultural and air-conditioning systems carry the CE mark, and the high demands under DIN EN ISO 9001 are met during planning and implementation.

All orders are fully pre-assembled in Iffeldorf, enabling swift deliveries to customers across Europe, Asia, and the USA.

# Individual Storage Solutions for Every Need

Each type of fruit and vegetable has unique storage requirements. Additionally, customer-specific requirements come into play, often influenced by their location and the prevailing climate. That is why at Gaugele, we do not offer one-size-fits-all storage solutions.

Instead, we tailor your storage solution to meet your individual needs.

Our manufacturing service goes beyond just storage planning, encompassing the production of every individual component. We place a high emphasis on durability, resource conservation, and adhering to legal standards.

## Room Ventilation for Box Storage

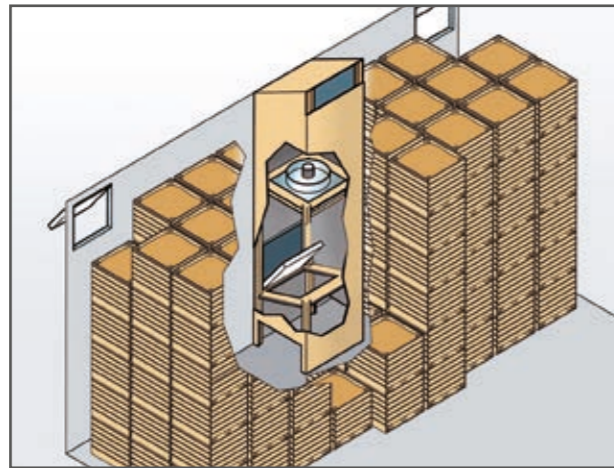

## Compact Cooling Systems

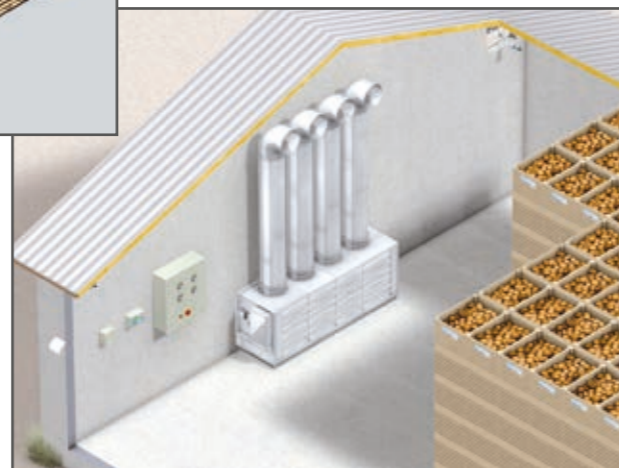

## Forced Ventilation for Box Storage

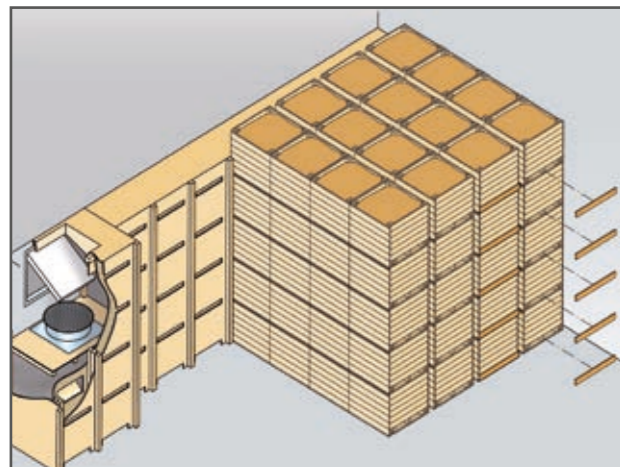

## Underfloor Ventilation with Individual Ducts

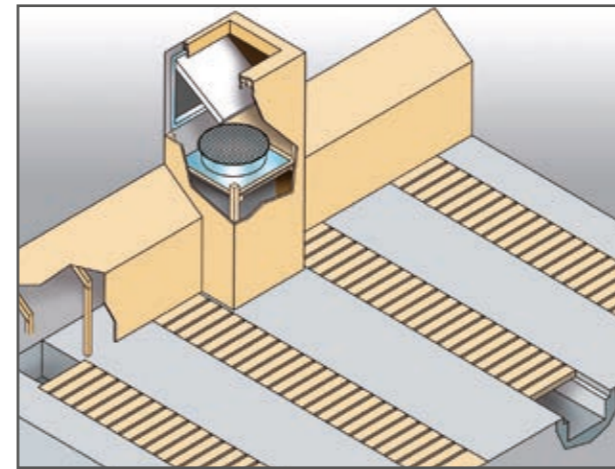

## Above-Floor Ventilation with Wood or Metal Ducts

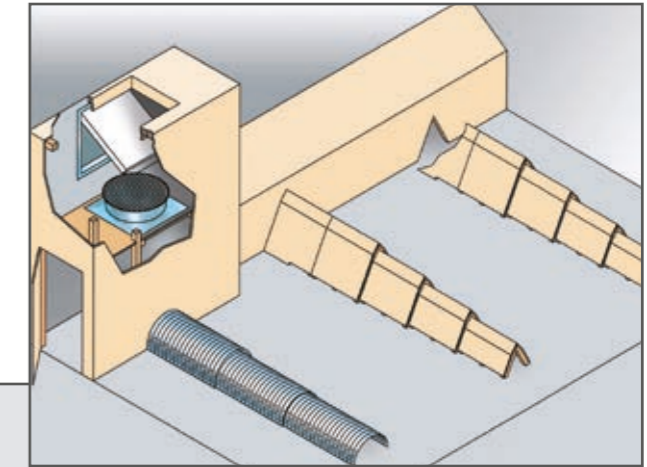

## Fully Slatted Floor

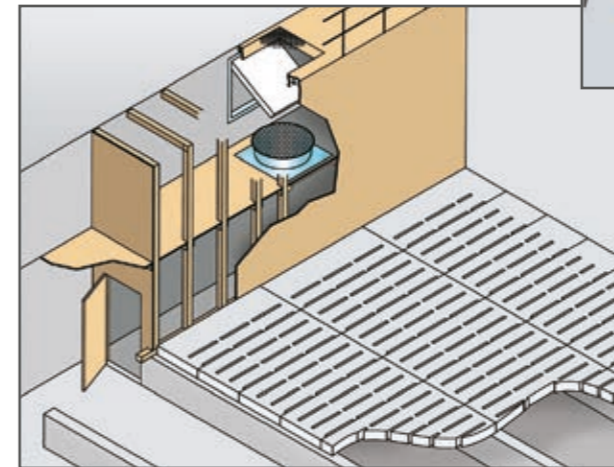

## Room Ventilation

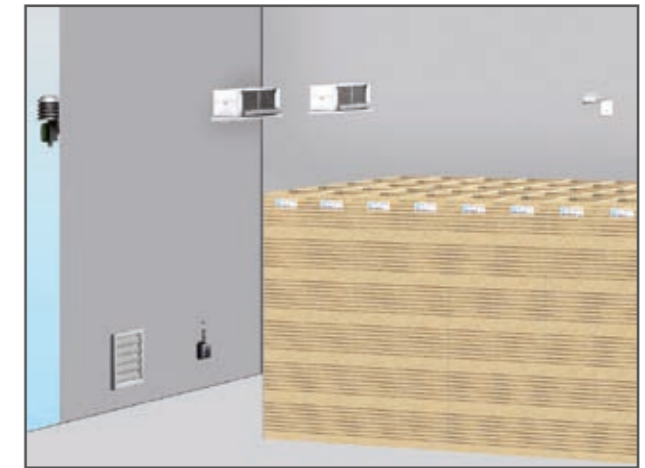

## Pressure Ventilation for Box Storage

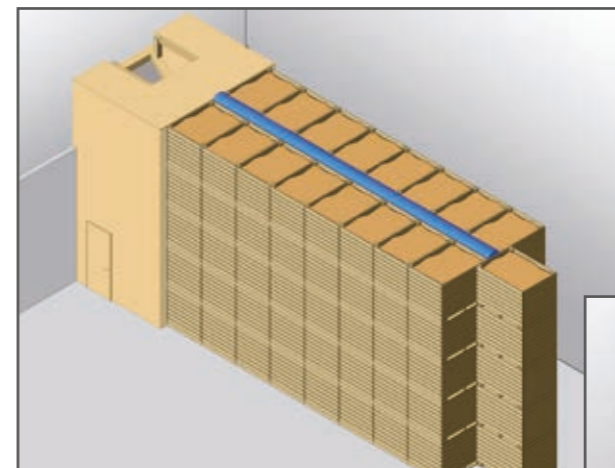

## Suction Ventilation for Box Storage

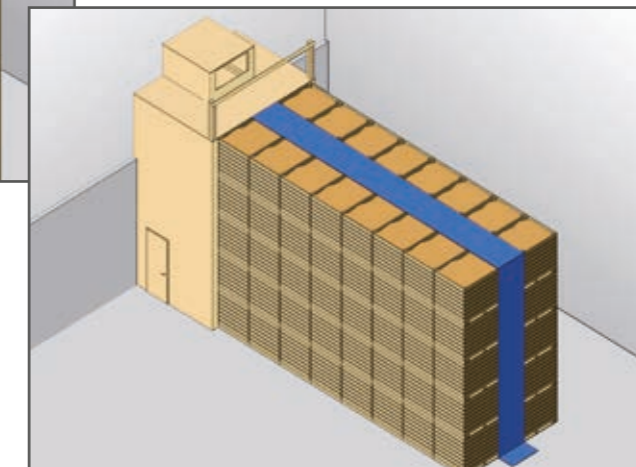

## Efficient Ventilation

The ventilation of fruits and vegetables is a science in itself: everything depends on the right mixture of outdoor and indoor air.

At Gaugele, we achieve this through sophisticated measurement and control technology, reliable damper technology, and high-performance fans – day and night throughout the entire storage season. The clear objective is to successfully balance moisture and temperature differences in various storage layers so that each product is given the optimal storage condition and can thus obtain top market prices.

**Pro Tip:**

Ensure wet potatoes are well-ventilated to achieve long and safe storage.

## Efficient Ventilation

# High-Performance Fans

The single-stage, two-stage, or infinitely variable Gaugele fans are powerful, maintenance-free, and operate quietly. The air flow rates are optimally tailored to the specific use case, ensuring to meet the needs of your product perfectly. The motor power ranges from 0.75 to 15 kilowatts. The housing is entirely made of flame-galvanized steel plate, with options for V2A or powder-coated finishes upon request, and the impeller is manufactured from corrosion-resistant aluminum casting. Alongside the robust, square mounting plate, all fans feature energy-saving diffusers.

We collaborate closely with renowned research institutes to continuously enhance our performance, cost-effectiveness, and sustainability. This partnership has enabled us to further optimize our energy-efficient high-performance fans.



**GV FANS**

Designed for use with flange motors, they are versatile, tried-and-true, and safe. Like all Gaugele fans, they come with an efficiency-boosting diffuser.



**FAN TYPE M**

Specifically engineered for high pressure (up to 600 Pa), offering stability and longevity; equipped with a flow-optimized diffuser.

## EC Technology

**20%** Energy Savings

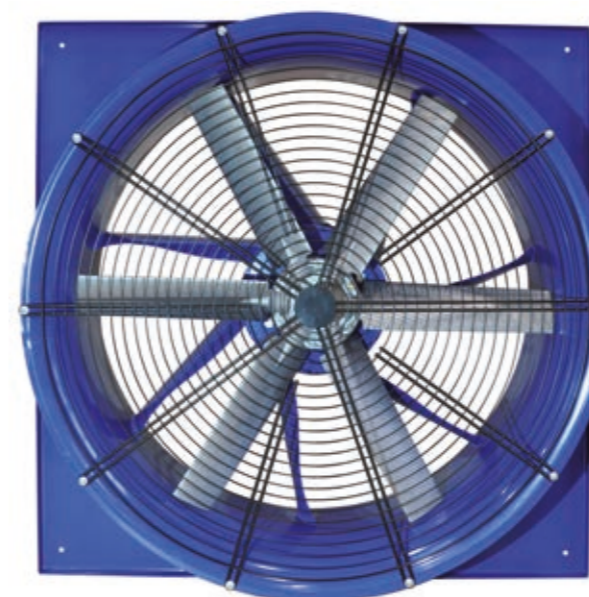

Due to intelligent control, the fan receives the right amount of power based on the rotor speed and the applied torque at every speed, allowing for up to 20% energy savings compared to conventional technology while maintaining the same performance. Additionally, the speed is infinitely variable. This product has therefore been awarded the “efficient green” seal, Gaugele’s recognition for efficient, environmentally friendly technology.

## Efficient Ventilation



### Mixed-Air Unit

Our state-of-the-art mixed air unit provides for the ideal ratio between indoor and outdoor air. With the help of a spindle motor with a self-locking worm gear (230 V, 0.12 kW), our controller regulates the flap position to achieve the right mixing ratio.

Gaugele mixed-air units offer:

- spindle motor with limit switches
- motor protection through bimetal sensor
- thrust tubes, engine mounting, and gear shift rods made of high-quality stainless steel

### Ventilation Flaps

Our ventilation flaps are made of fiberglass-reinforced polyester, ensuring exceptional durability. Their premium quality is further enhanced by a 120mm thick insulation core optimized for fire protection, V2A stainless steel hinges and built-in frames, along with a double stop feature for superior sealing and frost resistance.

Gaugele ventilation flaps are:

- safe and reliable
- robust and torsion-free
- vermin-proof
- impact- and shock-proof
- frost-proof



## Efficient Ventilation

Gaugele's spindle drives and multiple-flap drives ensure maximum operational dependability. With the incorporation of V2A stainless steel, they perform dependably even under high-humidity conditions.

Gaugele drive units offer:

- smooth-running electric engines
- optimum engine protection through bimetal sensors
- maintenance-free transmission system
- reliability and durability

### Spindle Drive

The Gaugele single-flap drive enhances operational reliability and allows for more nuanced control of the storage climate compared to a multi-flap drive.

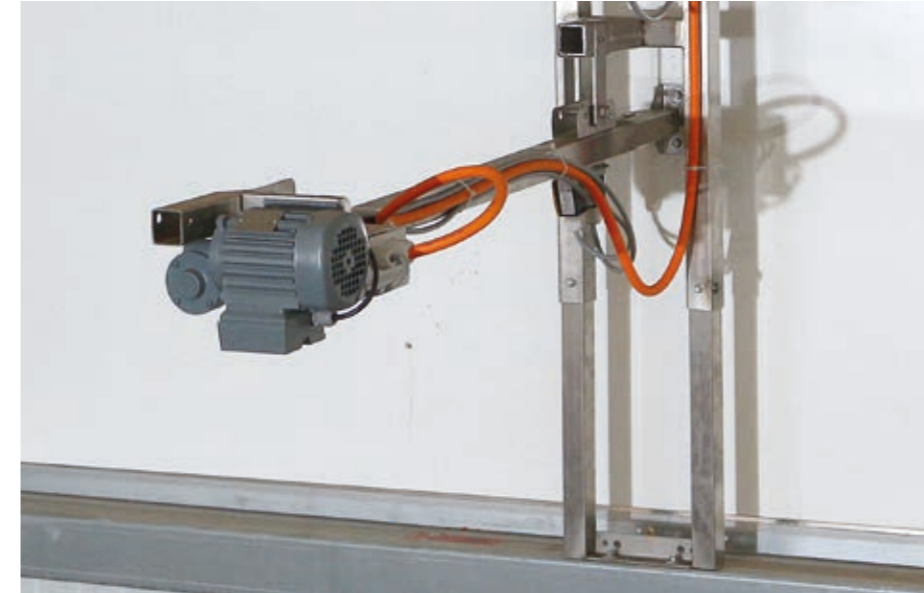

### Multiple-Flap Drive

The multiple flap drive allows for the opening of several flaps. It comes fully equipped with a limit switch and chain couplings to provide connection between motor and drive shafts via gear wheel and gear rack.



### WEATHER GUARD HOOD

Provides effective shielding for intake and exhaust air from weather elements. Also available in a sound-insulated variant.

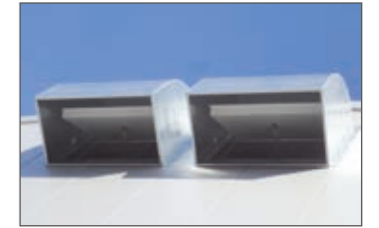

### ROOF ATTACHMENT KIT

Easy-to-assemble kit suitable for fresh air and exhaust air applications.



### STORAGE BOX

Ideal for storing onions, potatoes, and other types of vegetables. Available in various sizes according to customer preferences.



### WEATHER PROTECTION LOUVER

Made of aluminum, galvanized steel sheet, or V2A stainless steel.



### VENTILATION DUCTS

Semi-circular sheet metal ducts made of flame-galvanized steel plate for the ventilation of different products.



## Economical Cooling

Potatoes, carrots, onions, and fruit like it cool. Maintaining the right temperature ensures that the produce remains fresh for a long time, is optimally marketable and well preserved until the arrival of the new harvest.

The use of a professional refrigeration system optimizes cooling and drying regardless of weather conditions and ensures a consistent storage temperature even as outdoor temperatures rise. Installing such a system requires careful planning since each type of fruit behaves differently in storage. For instance, respiration and heat dissipation vary significantly depending on the type of fruit.

Gaugele has extensive experience in refrigeration system construction and understands the unique needs of various products. Therefore, we can calculate the customized cooling design for each product and storage type.

**Pro Tip:**  
Temperatures just above 0°C at maximum humidity ensure long-lasting freshness for potatoes, carrots, onions, and fruit.

## Economical Cooling



## Compact Cooler

Our compact cooler ready for connection comes with fans and a combined extern/recirculating air flap and is available in two variants: as a freestanding device (Model LKS) or as a wall-mounted unit (Model LKH). It stands out for its exceptional price-performance ratio and is suitable for box storage with room ventilation ranging from 30 to 1,500 tons per unit.

Ventilate and cool with just one unit, requiring minimal installation and maintenance effort.

efficient green

### LKS COMPACT COOLER

Cool and ventilate with one device, featuring a compact design with minimal installation and maintenance requirements.

These state-of-the-art coolers feature electronically controlled expansion valves and EC fans. The advantage of this technology is demonstrated by the Gaugele "efficient green" seal, signifying high energy efficiency – achieving greater cooling and air performance with the same energy consumption. Furthermore, cooling performance can be finely tuned (thanks to variable-speed compressors), allowing for gentle adjustments to the cooler's air temperatures. The airflow, managed by Gaugele processors, is energy-efficient and adapts to the actual air demand.



### LKH COMPACT COOLER

Perfect for upgrading existing storage facilities. Options with both indoor and recirculation air cooling are available.

Both types of units can also be provided for cold water or brine cooling. The LKS compact cooler can be easily implemented due to its enclosed design. The LKH compact cooler is also suitable for boxed storage (loose bulk products). In both cases, the compact and well-designed construction offers competitive pricing.

## Glycol Cooler

The new compact coolers are also available as a chilled water unit. They allow for the reduction of primary refrigerant usage.



# Direct Evaporating Cooling

We offer high-performance, ready-to-connect refrigeration systems with direct evaporative cooling, covering all performance levels. Like every technology from Gaugele, they meet all European standards and guidelines.

The compact design and few components allow for a cost-effective entry into cooling systems, especially when upgrading existing warehouses.

Compressors, cooled by suction gas and mounted on rubber vibration-damping strips, have a proven track record. This pump technology, designed for long-term durability, is characterized by consistent flow volume, high precision control, and quiet operation. When combined with a Gaugele control processor, the storage climate can be maintained with precision at all times.

The motors of the quiet-running axial fans operate using EC technology: due to intelligent control, the fan receives the right amount of power at each speed, depending on the rotor speed and torque, resulting in potential energy savings of up to 20% compared to conventional technology. Additionally, the rotation speed is infinitely variable.

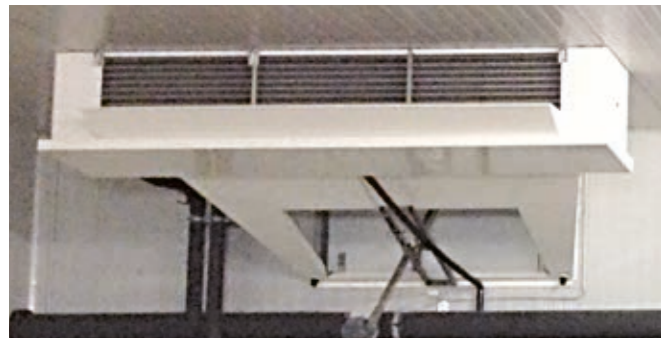

Ceiling-mounted air cooler with an integrated mixed air unit

Compact and strategically placed, it mechanically cools the air while mixing outdoor air with indoor air under precise processor control.



Ceiling Evaporator

An ideal lamella division prevents performance-reducing dirt accumulation and product drying that can compromise quality. Special variations of the ceiling evaporator designed for low clearance spaces above the storage stacks are also available. All models are fine-tuned to maintain the quality of your products.



Condenser

The condenser (recooler) releases the heat from the cooling medium to the surrounding area.

## Composite System

For large storage units, we recommend using an integrated system in which multiple compressors and cooling points are arranged in a refrigeration circuit.



Individual Condensing Units

Pre-installed refrigeration systems are tailored to your needs – optionally with roofing.

## Economical Cooling

Today, large-scale systems are operated using indirect brine cooling (glycol-water mixture) or chilled water cooling. In this process, a heat exchanger transfers the generated cold to the liquid medium, and a circulation pump delivers it to the air coolers in the storage room.

The benefits for you include reduced refrigerant usage and the ability to maintain very low temperature differences using 3-way valves. Additionally, the heat can be recovered via heat exchangers.

For your project, we offer customized units, ready for connection.

# Indirect

# Brine Cooling

**750 KW COLD BRINE UNIT**  
with screw compressor  
and heat recuperation.



## Economical Cooling

# Compact Chiller



The Gaugele MKL and MKS series of Compact Chillers redefine refrigeration systems: a crucial component is the so-called Multichannel Plate Heat Exchanger, which simultaneously serves as an evaporator, condenser, and internal heat exchanger, replacing three conventional heat exchangers. It stands out due to its distinctive feature, being the sole plate heat exchanger capable of accommodating multiple media in a single heat exchanger channel.

What makes the Compact Chiller especially innovative is its unique design, allowing it to operate with minimal refrigerant quantities and achieve peak efficiency.

# Refrigerated Container



In recent years, there has been a notable surge in demand for modular and efficient systems. This trend is driven by the advantages of rapid availability, flexibility, and minimal space requirements. Prefabricated container solutions save both time and costs.

### EVERYTHING INCLUDED

The fully preconfigured container includes cooling machines, hydraulics, and all other peripheral devices.



# ULO Technology

We provide comprehensive storage solutions for high-value goods like pumpkins, garlic, or pome fruit, offering fully airtight storage rooms using CA technology (Controlled Atmosphere) up to ULO (Ultra Low Oxygen) storage in various sizes. When combined with our cooling systems, we can maintain precise and product-specific storage conditions. This includes maintaining temperatures close to 0°C, high humidity levels, or achieving low oxygen levels with higher carbon dioxide content. Our TMC.10 controllers, known for their sensitivity and reliability, ensure that the storage climate is always optimal for the product, preserving its quality.

This ensures that your products stay perfectly fresh until the next harvest.



**SPECIAL AGRICULTURAL EVAPORATORS**  
for optimal results with minimal dehumidification.



# Condensation Drying

Condensation drying is considered the technology of the future, and at Gaugele, we've already embraced it in our portfolio. Our experts have invested their passion and dedication into developing this cutting-edge system.

Here is how it works:

- Evaporators draw moist air from fruits or vegetables and cool it down.
- The moisture condenses and is removed.
- The air is then reheated and can once again absorb moisture.

Crucially, the reheating process is both practical and cost-effective, using the heat generated during the cooling process. Moreover, condensation drying runs solely on electricity, eliminating the need for expensive gas.

The result:  
enhanced quality with reduced energy expenses



**OPTIMIZED CLIMATE**  
Customized design for best results.



**BLOCK IN BLOCK**  
Cooling and heating coils in one unit for uniform drying.

## Intelligent Controlling

Gaugele's intelligent processor-controlled regulation technology ensures that the goals set for the storage season, like daily product cooling, are achieved in a way that is gentle on the products and highly reliable. This technology takes advantage of short-term weather-related temperature changes to effectively manage the storage climate. When combined with a refrigeration unit, it enables accelerated drying regardless of weather conditions, and the storage duration can be extended until the next harvest.

Gaugele's ventilation processors consistently set new benchmarks, particularly in terms of ventilation results and technological capabilities. We bring together decades of experience in handling stored goods with state-of-the-art technology, delivering consistently positive impacts on cost-effectiveness and energy efficiency. We enhance energy efficiency through measures such as peak power monitoring and a smart energy management system that incorporates self-generated power.

**Pro Tip:**  
The drying process with air heating combined with intelligent cooling is highly efficient.

## Intelligent Controlling

# Optimum Storage Climate

## TMC.10 Controller

The intelligent Gaugele control algorithm analyses the temperature and humidity trends in the surroundings to efficiently manage the storage while preserving product freshness. Depending on the stored product and storage phase, there are up to 50 different programs available. An intuitive touch control interface allows for quick and effective adjustment of each storage location to meet your product's specific requirements. The 10-inch screen provides a comprehensive overview of all crucial storage parameters, enabling precise monitoring and documentation. High-resolution graphs and tables offer the capability to identify trends and take preventative action.



The TMC.10 incorporates real-time performance monitoring for precise energy management. With the built-in network connection, you have the option to securely check the condition of your goods worldwide at any time.

Furthermore, updates or customer-specific configurations can easily be loaded onto the TMC.10 via a USB stick, and data and settings can be exported. Due to a specific system structure, you can also install multiple TMC.10 units in a storage complex and control every storage location from any device.



## Gaugele Online App

You can access all the functions of the TMC.10 via the Gaugele Online App on your smartphone (both Android and iOS). This allows you to monitor your stored goods and adjust ventilation parameters from anywhere, providing the same ease and convenience as using the TMC.10 or the desktop application.



## Intelligent Controlling

Our experienced technicians have primarily prioritized one thing during the development of our control and regulation systems: achieving maximum cost-effectiveness.

As a result, we have created intelligent processor-controlled regulation technology that leverages even short-term weather-related temperature changes to optimize storage climate. Depending on the storage requirements of your products, fan and running performance are automatically adjusted to the current energy cost situation.

# Smart

# Energy Management

Energy efficiency is also a fundamental aspect, achieved through measures such as peak power monitoring or a well-designed energy management system that includes self-generated power.

Your advantages:

- utmost reliability in daily cooling and ventilation
- excellent cost-benefit ratio
- convenient app for climate control accessible via smartphone, tablet, or computer



## Fast Response

# We are Here to Assist You

When it comes to service, Gaugele places a strong emphasis on close customer relationships – quite literally. Our employees in Germany, Austria, Switzerland, and Romania ensure direct and prompt customer contact.

Our experts handle the commissioning of the systems and provide on-site training for your personnel operating the equipment. Additionally, we offer regular training sessions for operators, either at our training center located at the Iffeldorf company headquarters or at your location. Our professionals are eager to share technical advancements and new insights that could be relevant and beneficial to you.

As a Gaugele customer, you will continue to enjoy comprehensive service even after the project is completed. This includes reliable maintenance and prompt spare parts supply. Moreover, if desired, our experts can remotely monitor and support your system.

This ensures that your storage facility remains consistently reliable and ready for operation.

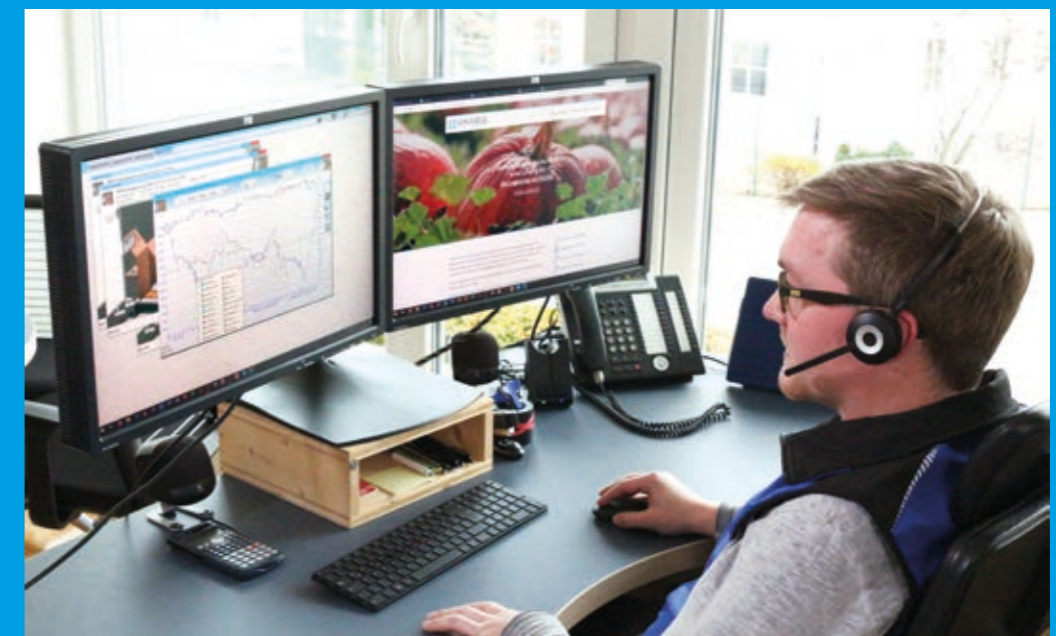

# One-Stop Solution

## Natural Refrigerants

Gauele has always been committed to using so-called 'natural refrigerants.' These refrigerants occur naturally and have little to no adverse effects on our environment. In technical terms, this translates to them having a low Global Warming Potential (GWP).

Unlike many household and professional refrigeration devices that use F-gases, our products completely avoid them. F-gases have a climate-damaging impact which is several thousand times higher than that of CO<sub>2</sub>, leading the EU to enact the F-Gas Regulation some years ago. This regulation aims to reduce F-gas usage by 21% by 2030.

Our commitment to you includes:

- use of natural refrigerants
- minimized use of refrigerants to protect the environment
- years of experience in the field of natural refrigerants
- a general preference for environmentally friendly materials in our products
- highest product safety standards

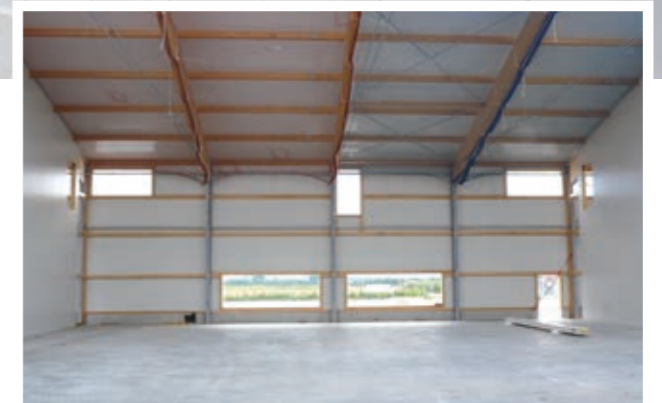

The construction of a new storage facility begins with an optimal storage concept. When determining size, location, equipment, and transport routes, we always focus on the requirements of your products. Additionally, our aim is to minimize operational expense. This makes us the ideal partner for your potato, vegetable, or fruit storage facility – whether you are planning a turnkey new construction, a renovation, or a modernisation project.

**One particularly convenient aspect is our in-house planning department, which takes your project from a first draft to a submission-ready plan, creating both building and storage plans. In hall construction, we collaborate with recognized specialists – or, of course, with the construction company of your choice.**

To complement our offerings, we provide a wide range of sorting and storage products. This includes assistance with the planning and procurement of items such as receiving hoppers, telescopic conveyors, unloading distributors, sorting machines, and reading devices, among others. Furthermore, we offer high-quality and functional storage accessories, ranging from storage crates, sheet metal channels, wooden hurdles, and weather protection louvers to roof extensions, retaining walls, cold room doors, and gas heaters. When it comes to setting up efficient conveyor systems, we partner with established experts to ensure the seamless transportation of your stored goods.

## Our Locations

In addition to our headquarters in Iffeldorf, south of Munich, and our North location in Cuxhaven, numerous employees in Germany, Austria, Switzerland, and Romania ensure direct and prompt customer contact.

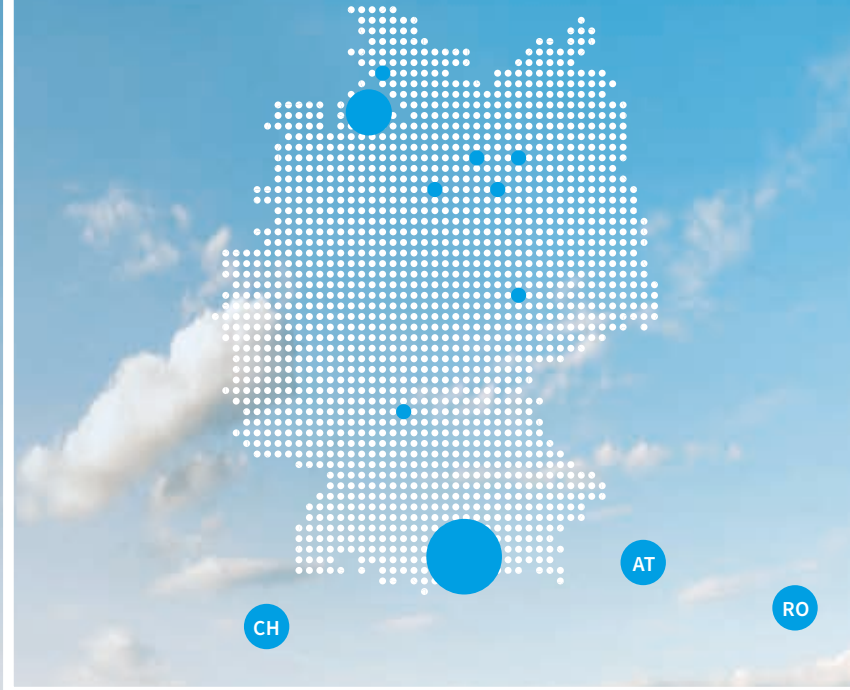

[www.gaugele.com](http://www.gaugele.com)

Gaugele GmbH | Seeshaupter Straße 20 | 82393 Iffeldorf | Tel. +49 8856 9366-0 | Fax +49 8856 9366-123 | [info@gaugele.de](mailto:info@gaugele.de)

